

**NOTICE DE MONTAGE
INSTRUCTIONS / HANDLEIDING**

La Plancha Française GAZ

Réf./Ref. PLFO250DC



Merci d'avoir acheté ce produit LE MARQUIER© labellisé Origine France Garantie !

Consulter cette notice avant l'utilisation

Thank you for purchasing this product with certificate of guaranteed French origin! Consult this instruction manual before use.

Bedankt voor uw aankoop van dit product met gecertificeerd garantielabel 'Product vervaardigd in Frankrijk'! Raadpleeg deze handleiding vóór gebruik

Pièces incluses Supplied parts / Meegeleverde onderdelen :

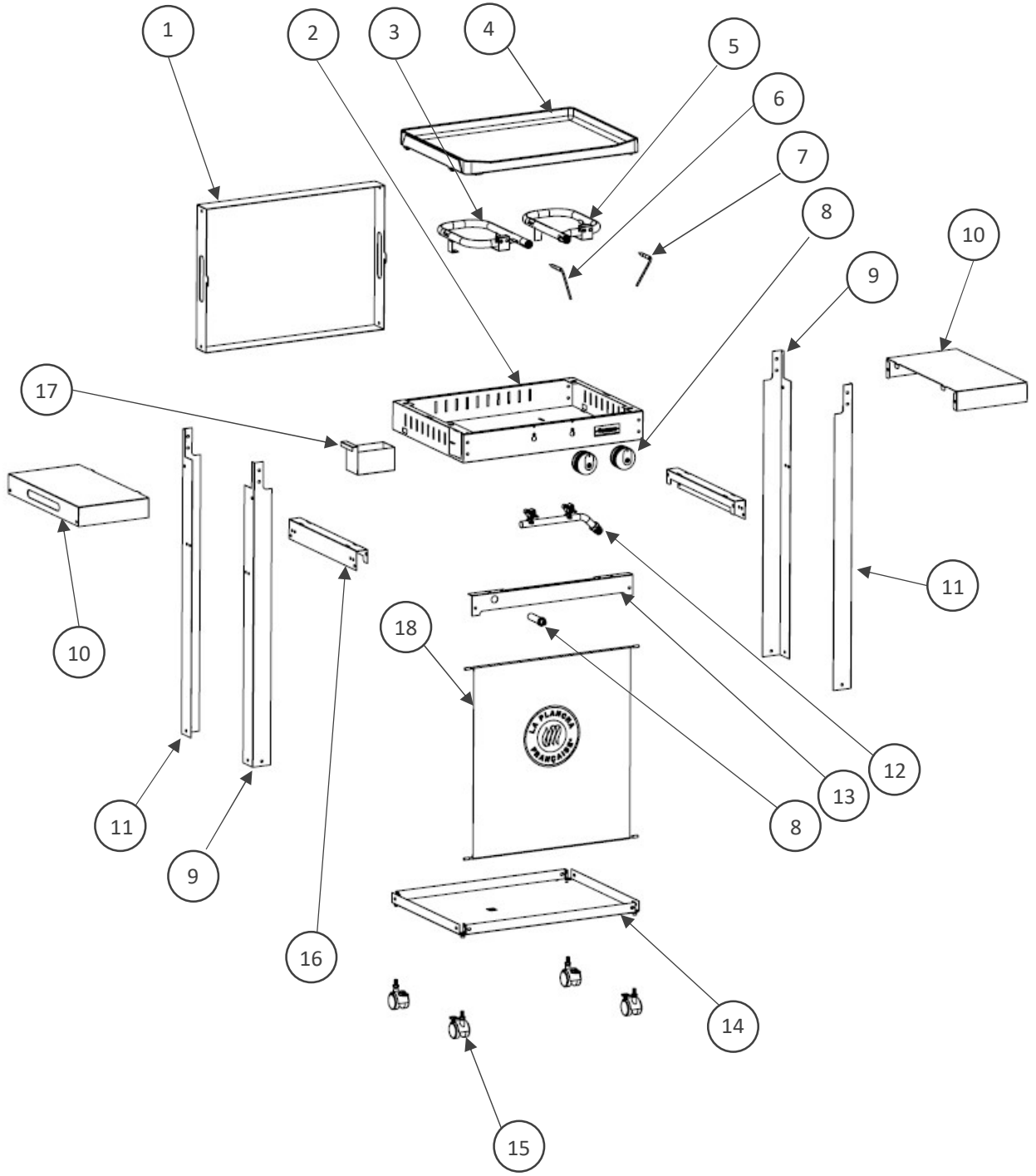

N° Repère	Réf. Pièce	Description	Qté
1	1951009 A	Couvercle / Hoods / Deskel	1
2	1951001 A	Plancha / Plancha / Plancha	1
3	COM0221	Bruleur Gauche / Left Burner / Linker brander	1
4	PLQ0014	Plaque de cuisson / Cooking plate / Kookplaat	1
5	COM0222	Bruleur Droit / Right Burner / Rechter brander	1
6	COM0227	Bougie Clip Lg=200mm / Clip Spark Plug Lg=200mm / Clip kaarsen Lg=200mm	1
7	COM0231	Bougie Clip Lg=400mm / Clip Spark Plug Lg=400mm / Clip kaarsen Lg=400mm	1
8	POC0023	Pochette de vis Plancha Française Gaz/ Screw pocket Plancha Française Gaz / Schroefzak Plancha Française Gaz	1
9	1951005 A	Pieds avant gauche / arrière droit Front left / rear right foot Voet links voor / rechts achter	2
10	1951006 A	Tablettes / Tablet / Tablet	2
11	1951002 A	Pieds avant droit / arrière gauche Front right / rear left foot Voeten rechts voor / links achter	2
12	COM0235	Assemblage Gaz	1
13	1951003 A	Tôle avant / Front Sheet / Voorblad	1
14	1951004 B	Plateau inférieur Lower tray / Onderblad	1
15	COM0209	Roues Ø40 / Wheels Ø40 / Wielen	4
16	1951007 A	Renfort latéral / Lateral reinforcement / Laterale versterking	2
17	AGR95	Mug / Mug / Mog	1
18	COM0234	Rideau / Curtain / Gordijn	1

POC0023

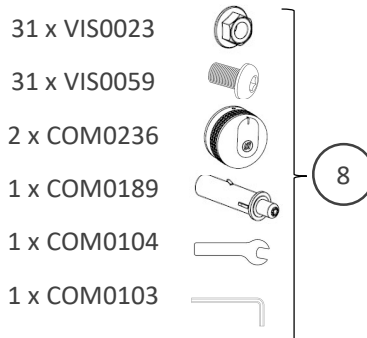

Avant de commencer le montage retirer le film de protection sur la plancha.
 Before the assembly remove cover foil of the plancha.
 Verwijder voordat u met de montage begint de beschermfolie van de plancha.

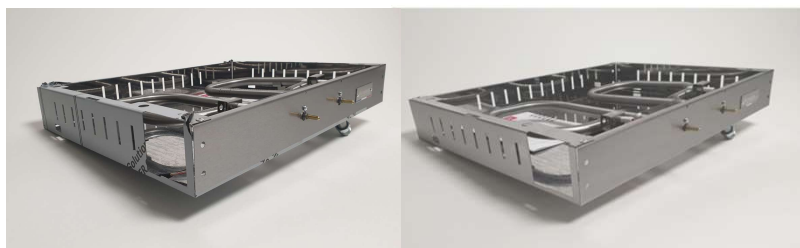

Montage Assembly / Montage :

1.

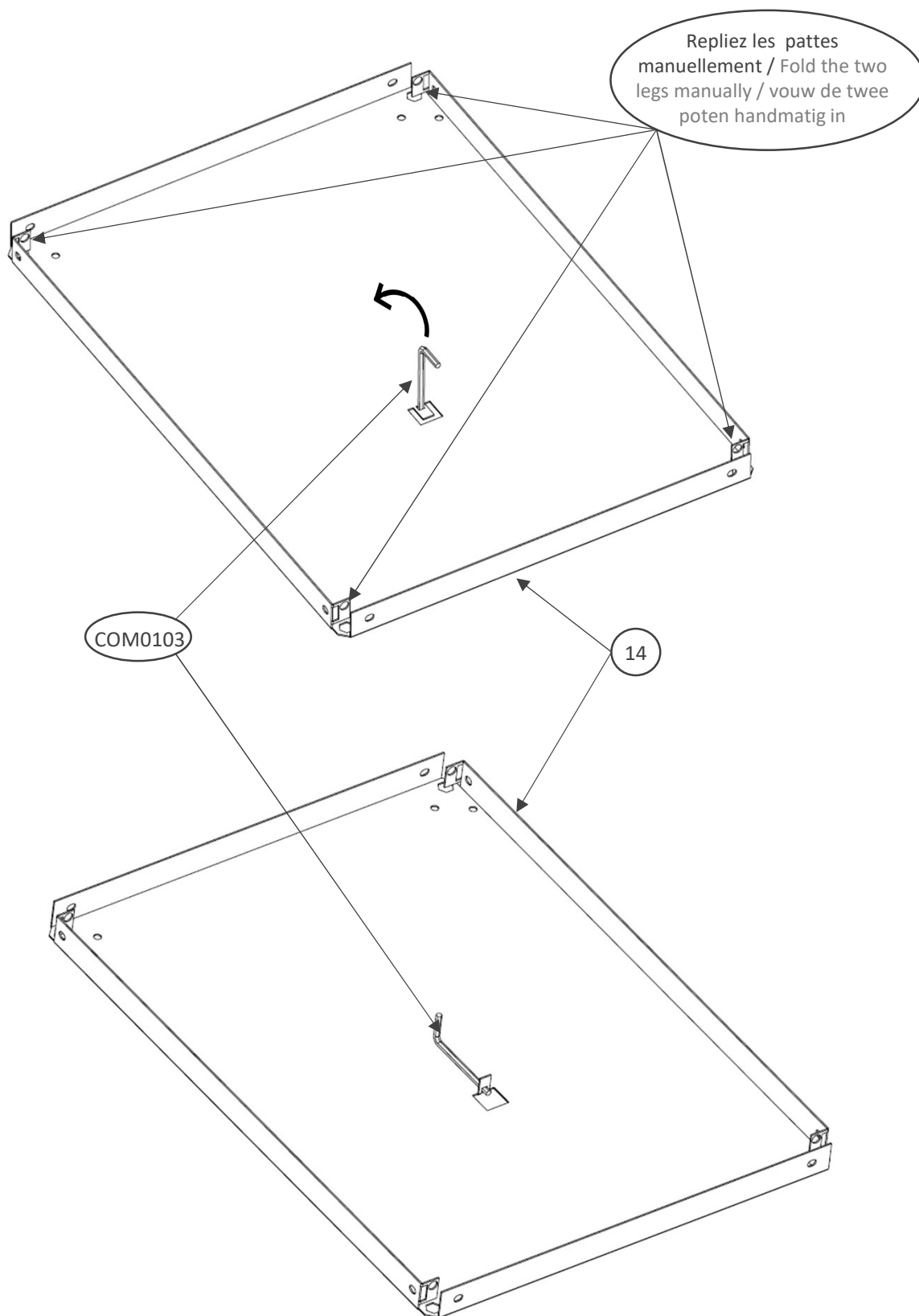

2. 8 x  8 x 

Serrer les vis / Ecrous à la main
Tighten the screws / nuts by hand
Draai de schroeven / moeren met de hand vast

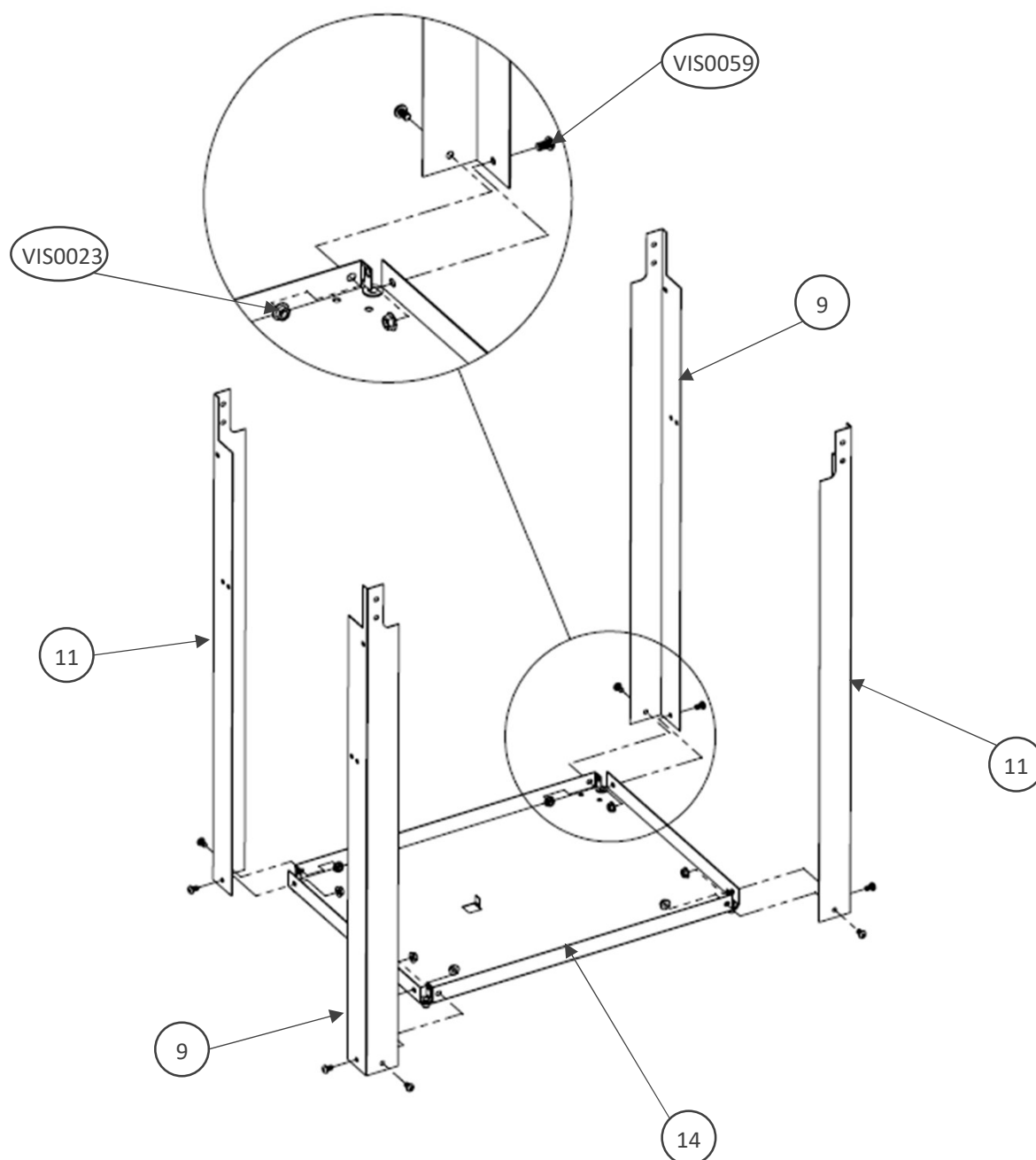

3. 8 x 

8 x 

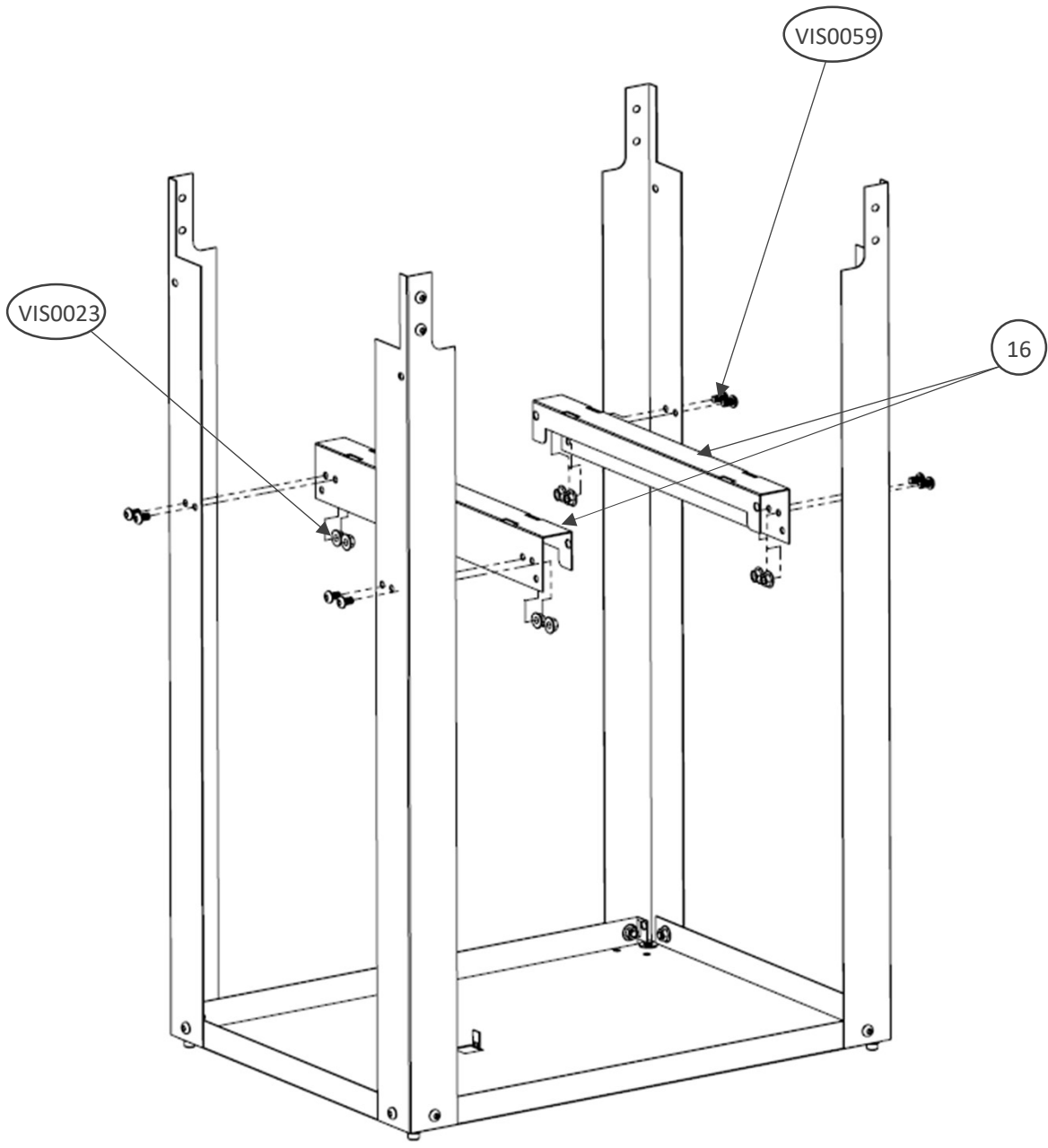

4.

8 x 

8 x 

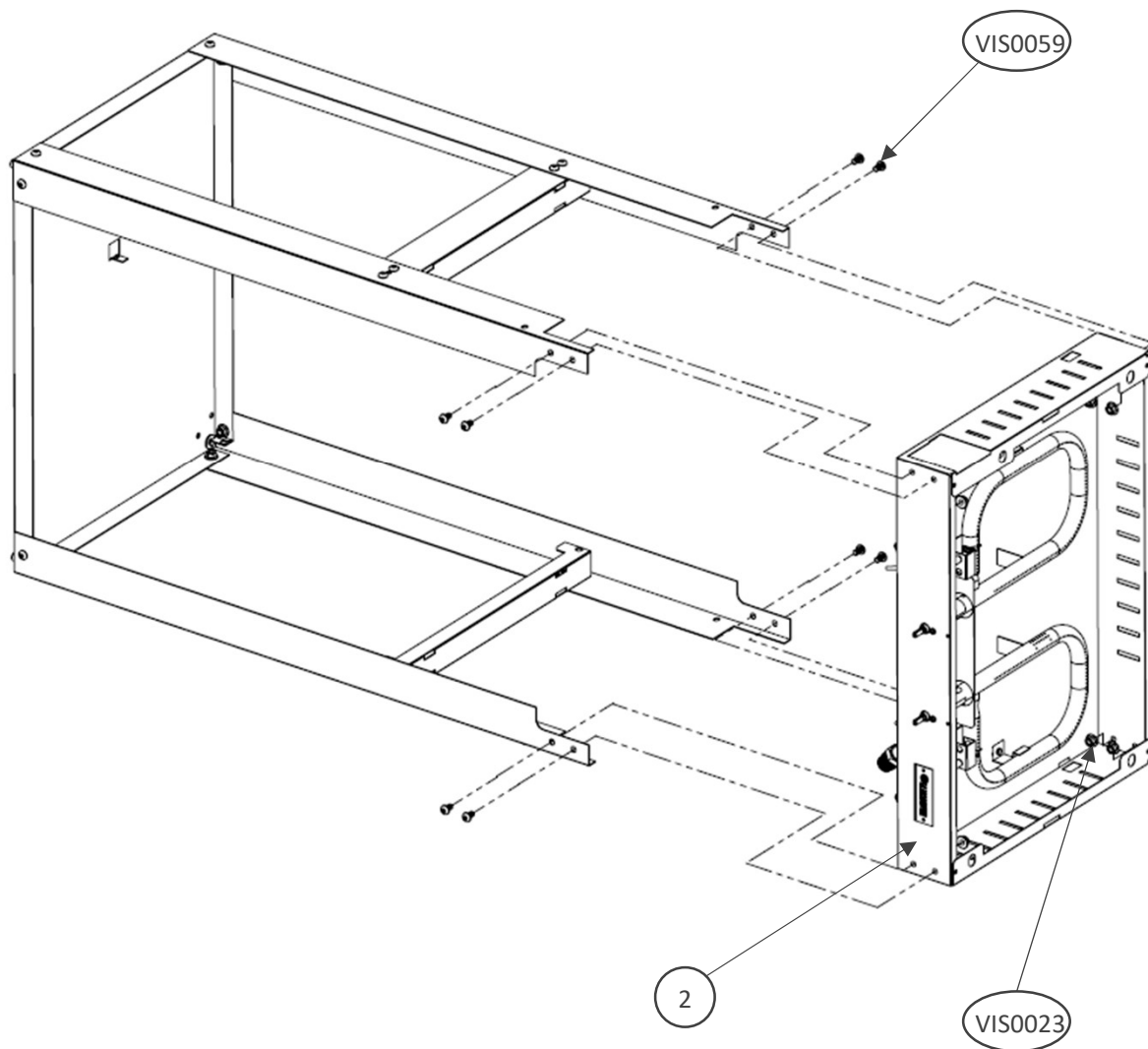

Après cette étape serrer les vis / écrous avec les clés fournies

After this step tighten the screws / nuts with the keys provided

Draai na deze stap de schroeven / moeren vast met de meegeleverde sleutels

5.

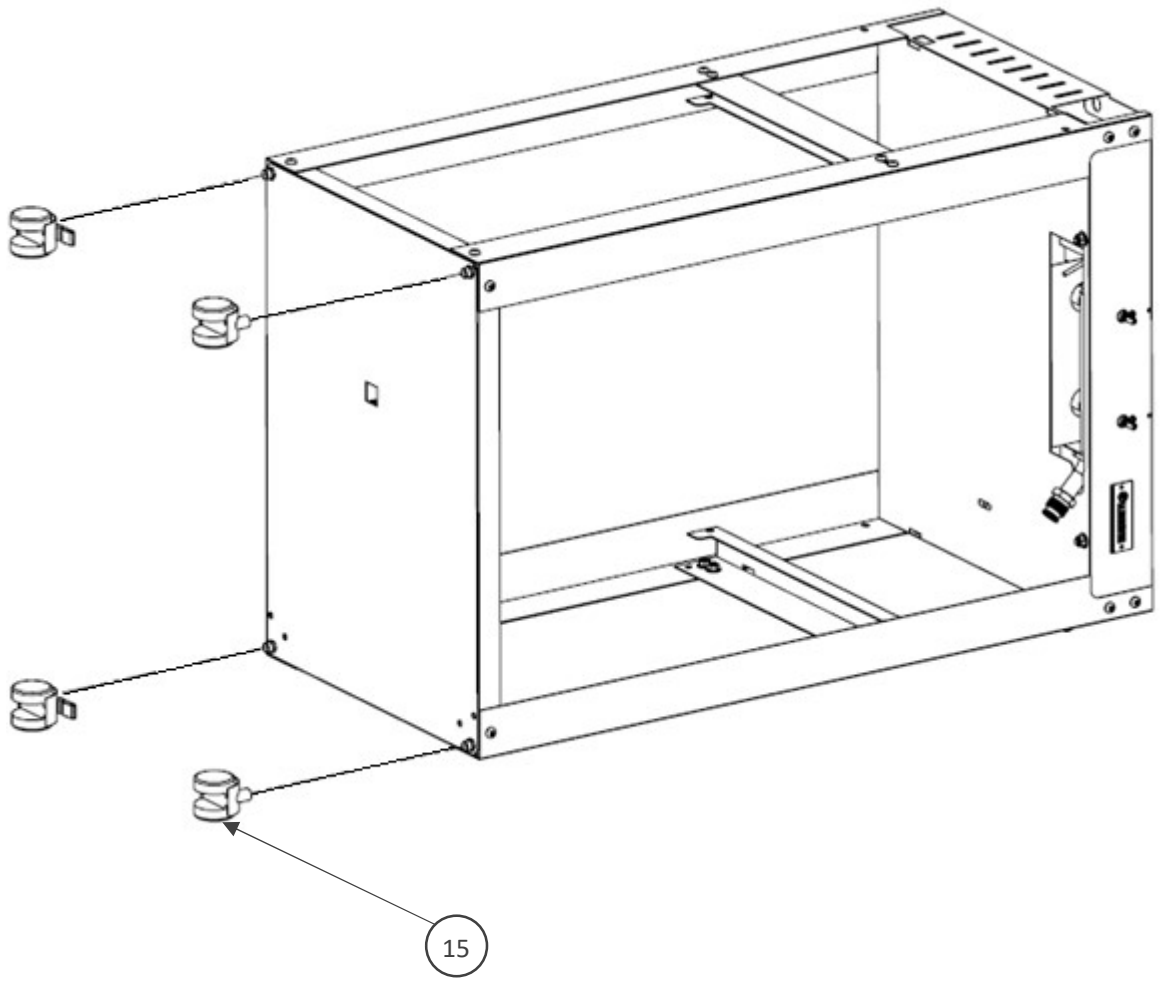

6. Montage du flexible

Raccordez le flexible gaz à la plancha au niveau du raccord d'alimentation, raccordez le flexible, raccordez le détendeur sur le flexible puis sur le récipient gaz en suivant les indications fournies avec le flexible et le détendeur.

Connect the gas hose to the plancha at the supply connection, connect the hose, connect the regulator to the hose and then to the gas container following the instructions provided with the hose and the regulator.

Sluit de gasslang aan op de plancha bij de toevoeraansluiting, sluit de slang aan, sluit de regelaar aan op de slang en vervolgens op de gasfles volgens de instructies die bij de slang en de regelaar zijn geleverd.

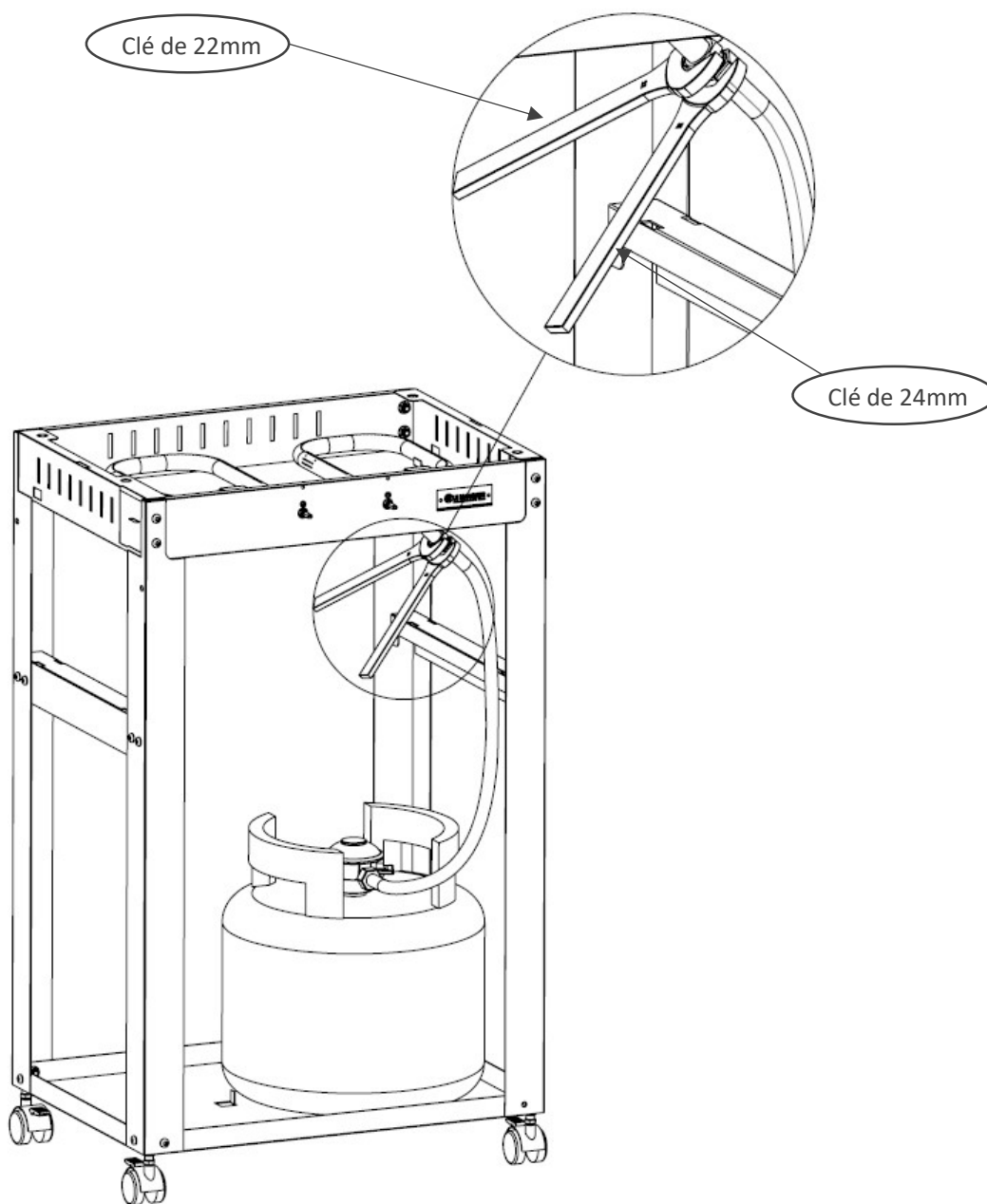

7.

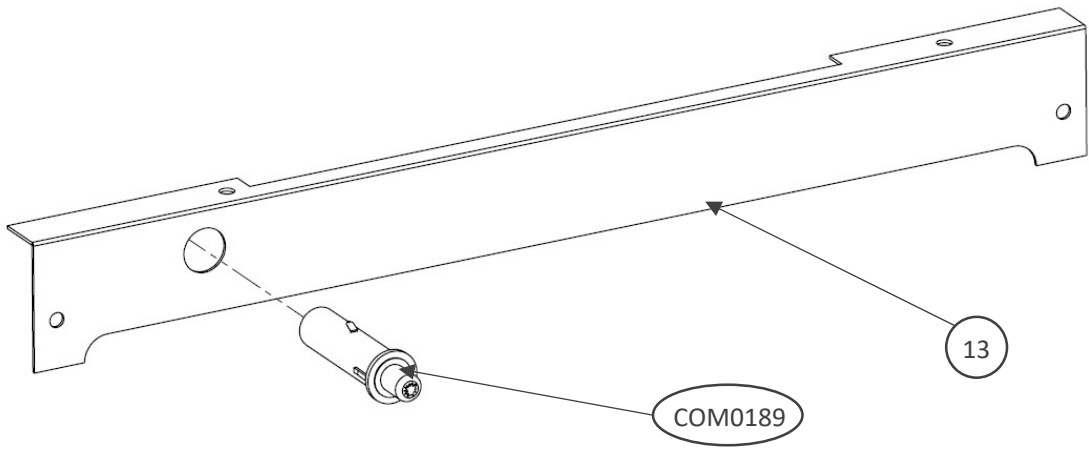

8.

2 x  2 x 

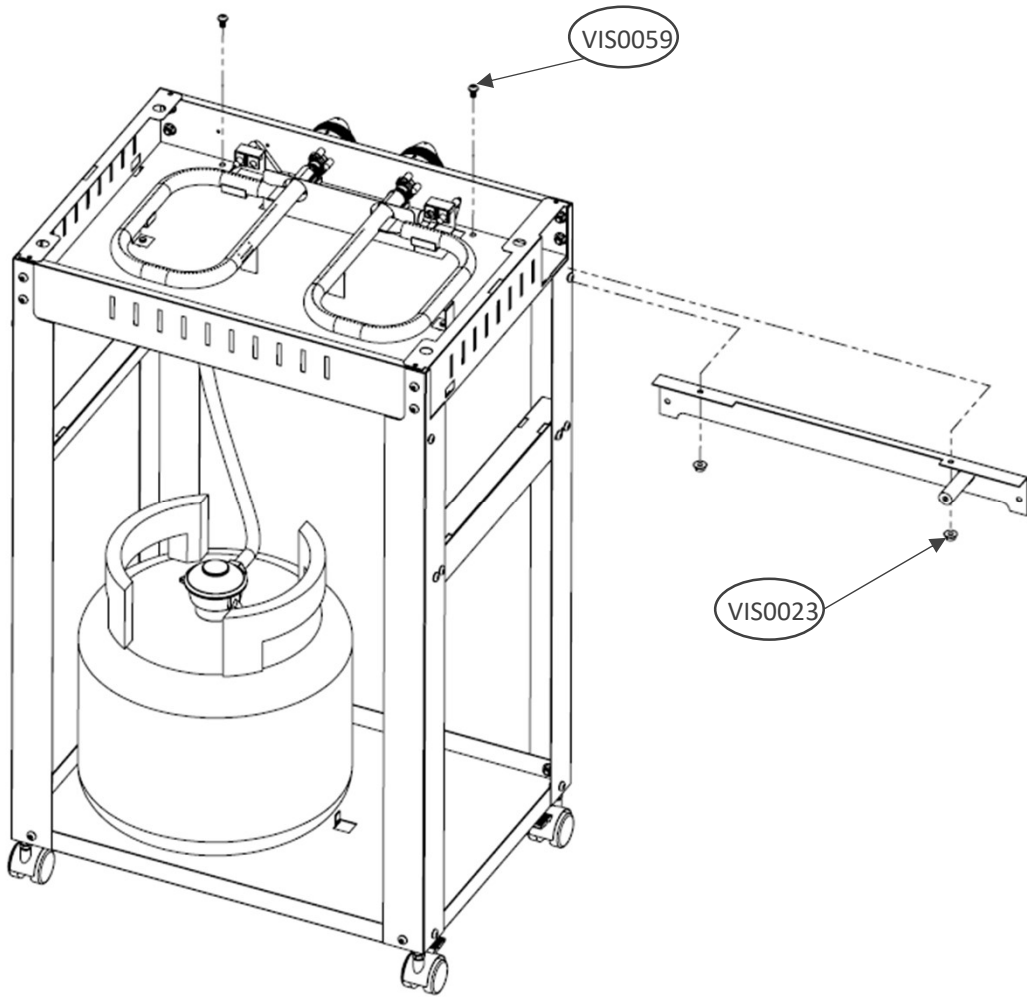

9. Effectuer les branchements des électrodes

Make the electrodes connections

Maak de elektrodeverbindingen

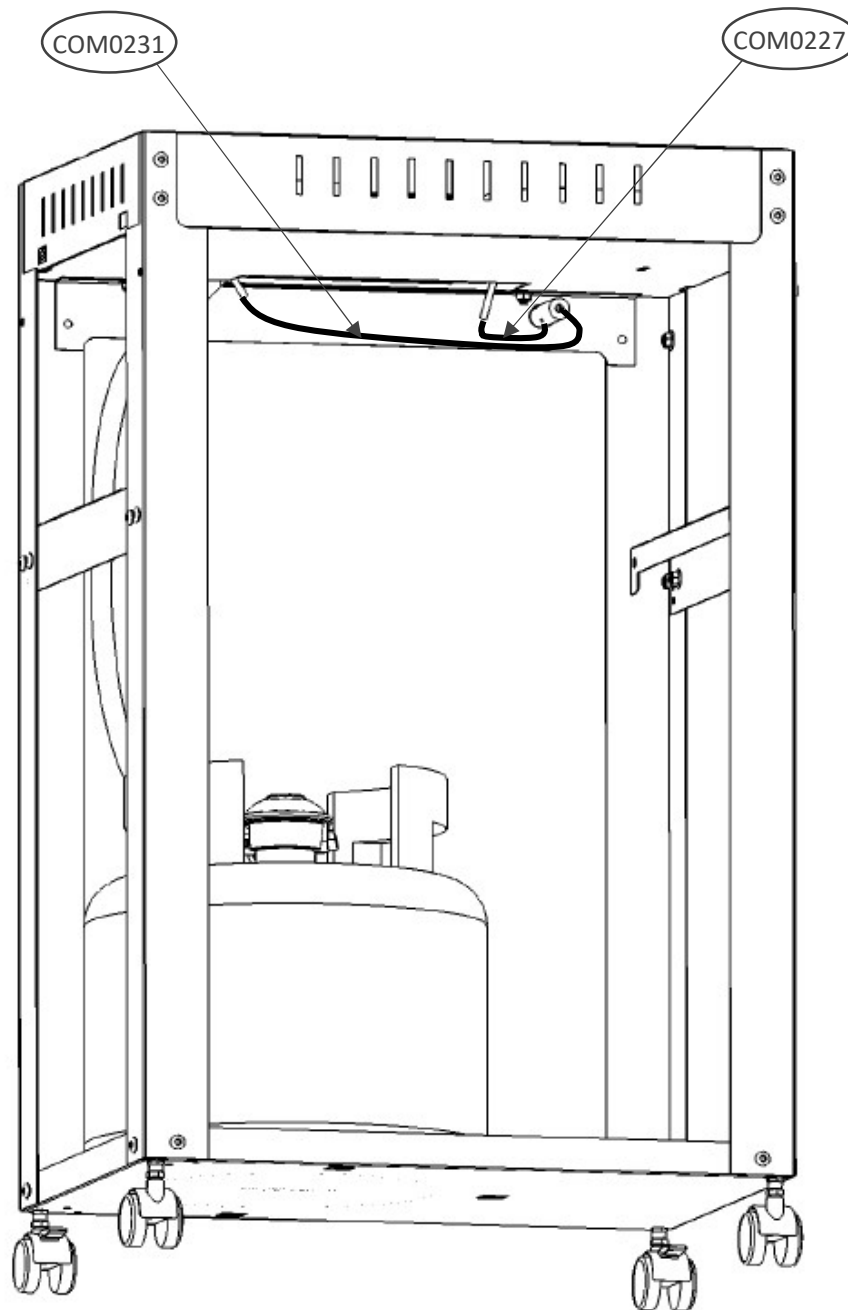

10. Montage sans verrouillage

Assembly without locking / Montage zonder vergrendeling

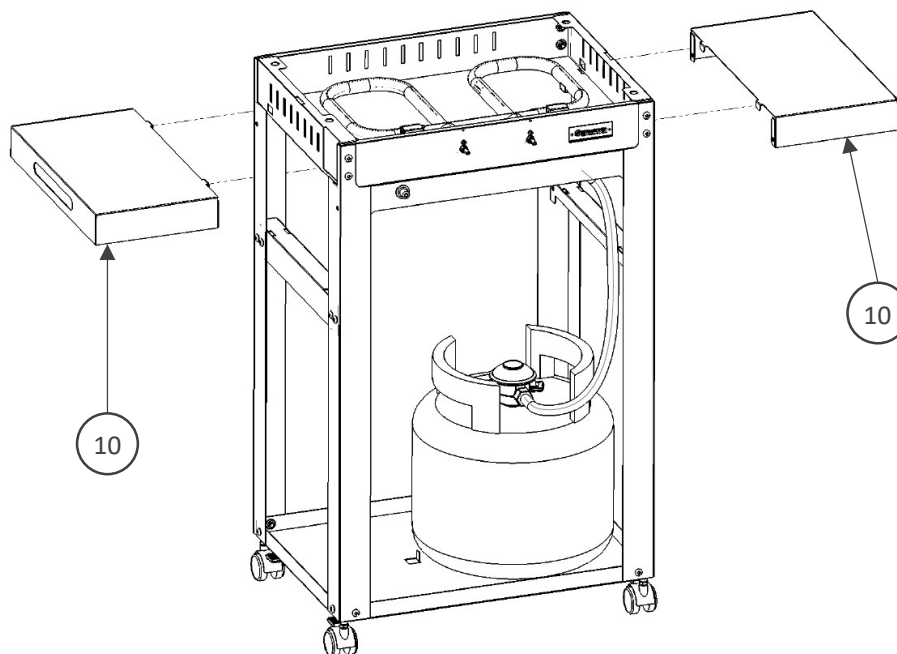

Dans le cas du montage sans verrouillage ne manipulez pas l'ensemble par les tablettes.
In the case of assembly without locking, do not handle the assembly by the shelves.
Bij montage zonder vergrendeling de montage niet aan de planken vastpakken.

11. Montage avec verrouillage

Assembly with locking / Montage met vergrendeling

4 x 

4 x 

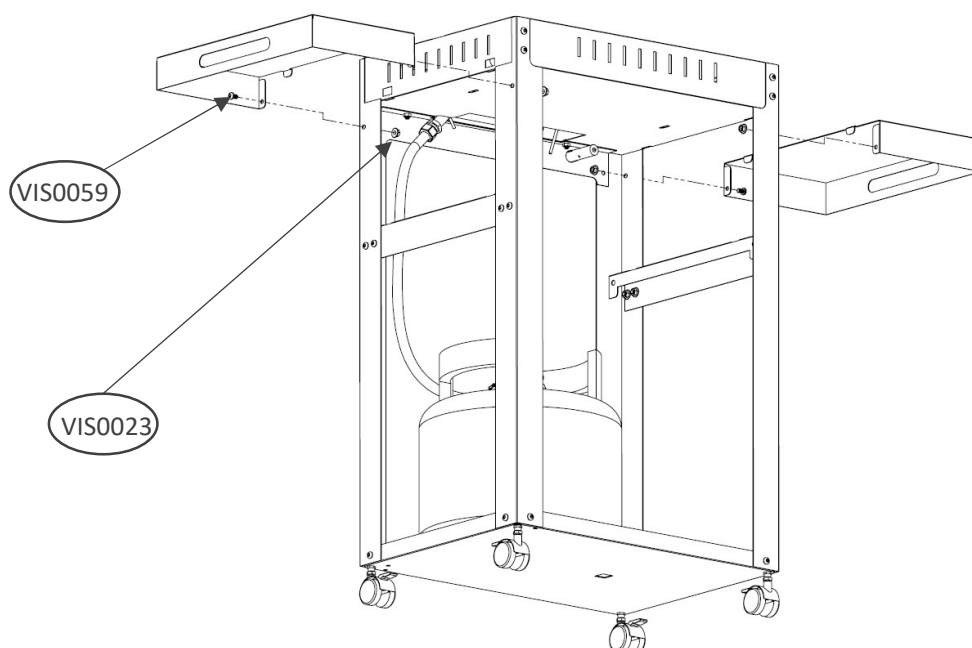

12.

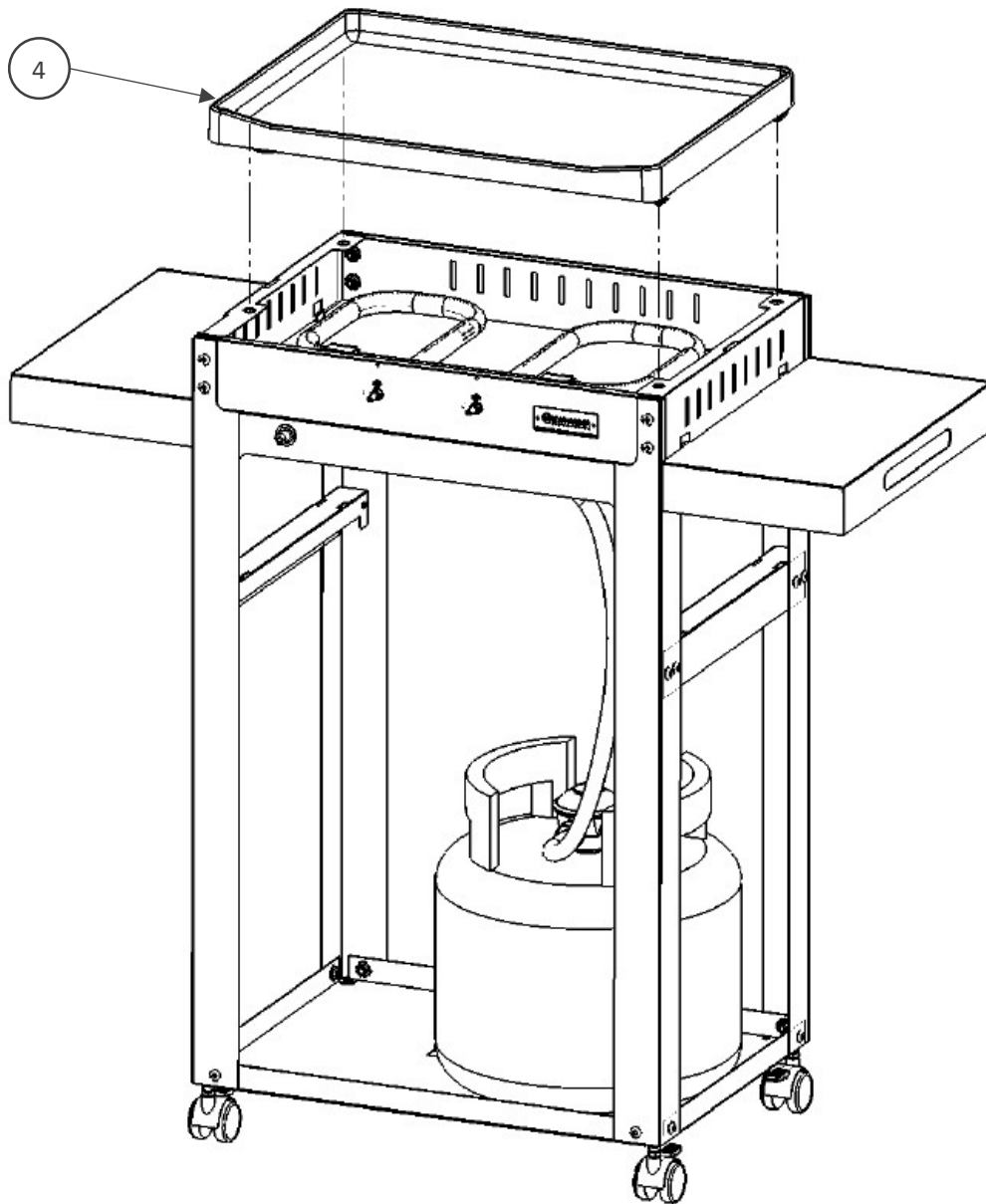

13.

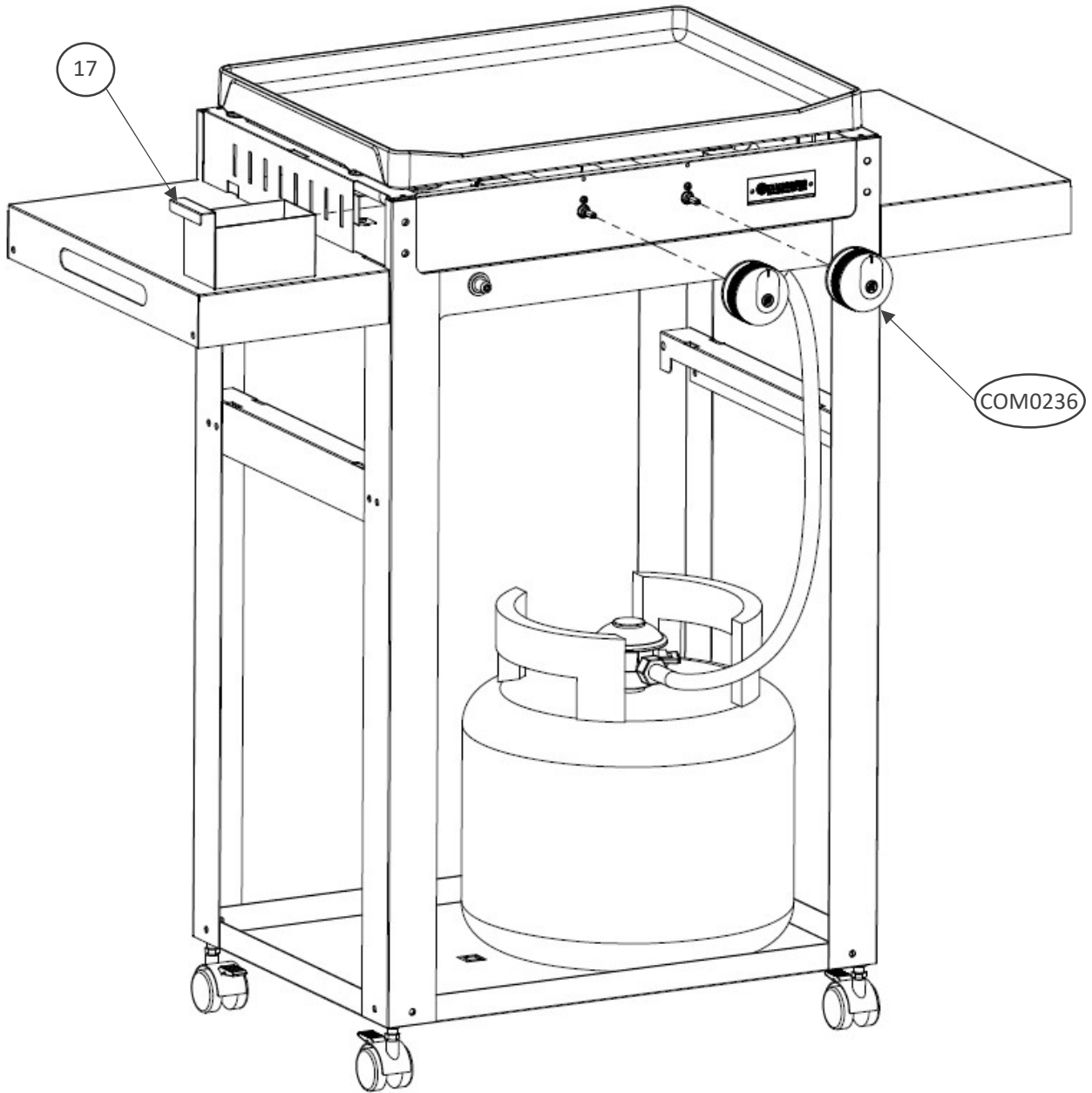

14. a

NB : Ce produit est un couvercle de protection, ne pas utiliser lors de la cuisson !
NB : This product is a protective cover, do not use when cooking !
NB : Dit product is een beschermingsdeksel, niet gebruiken tijdens het hoken!

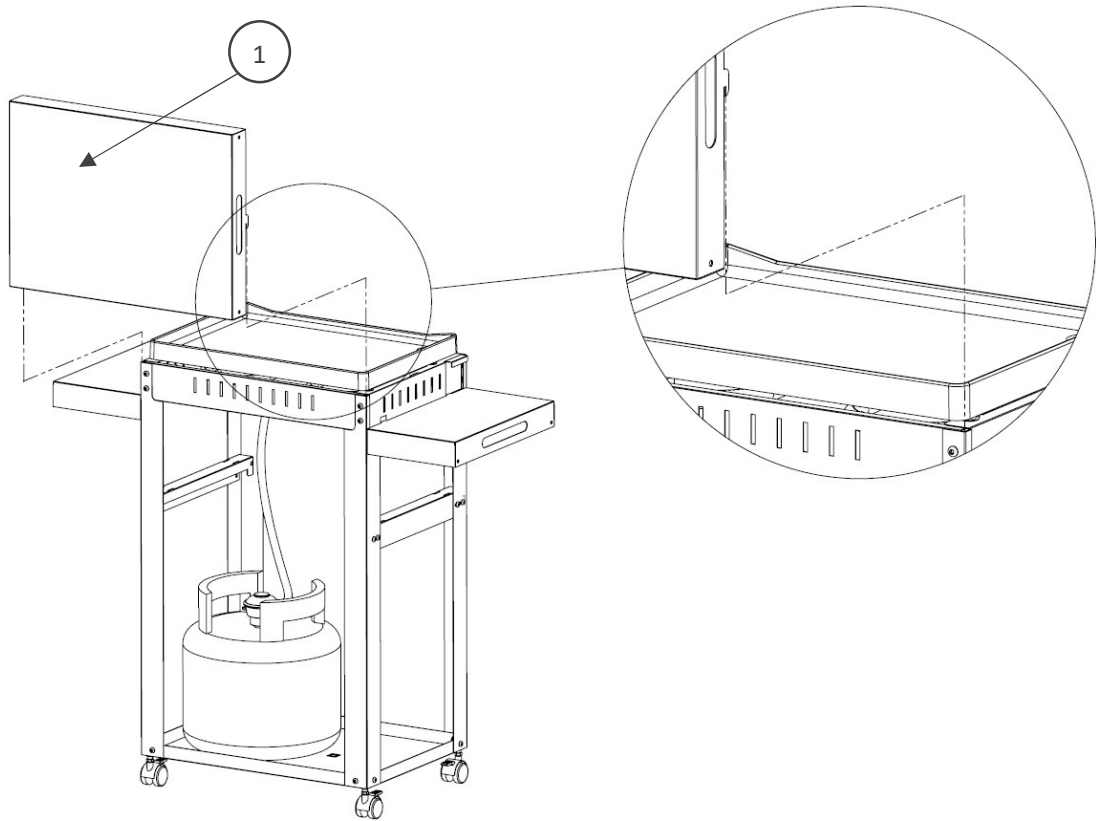

14. b

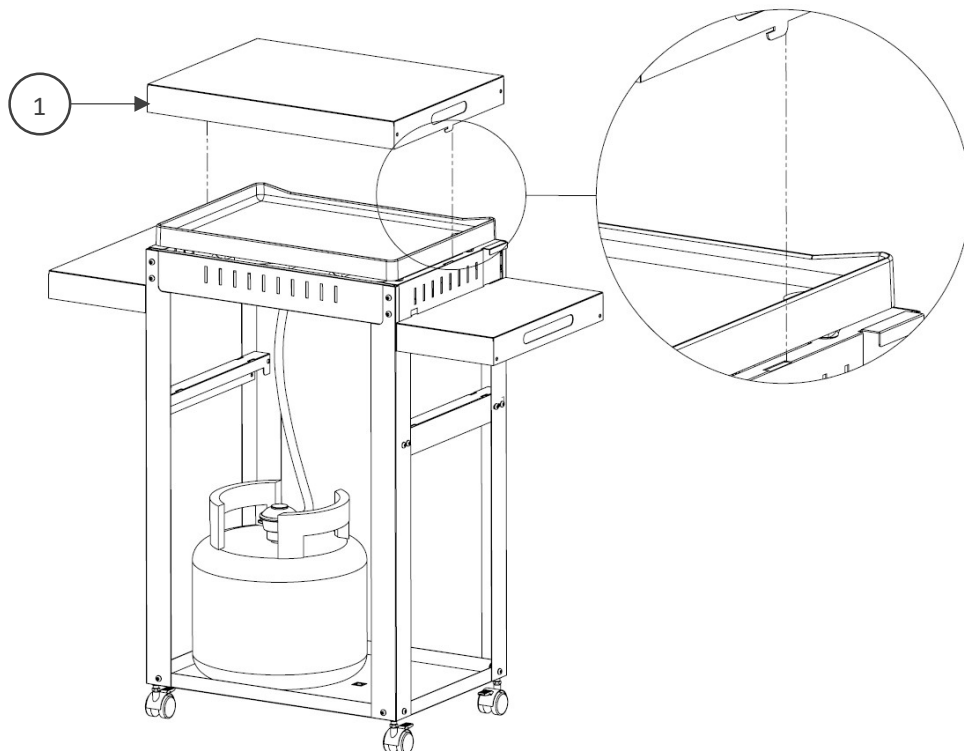

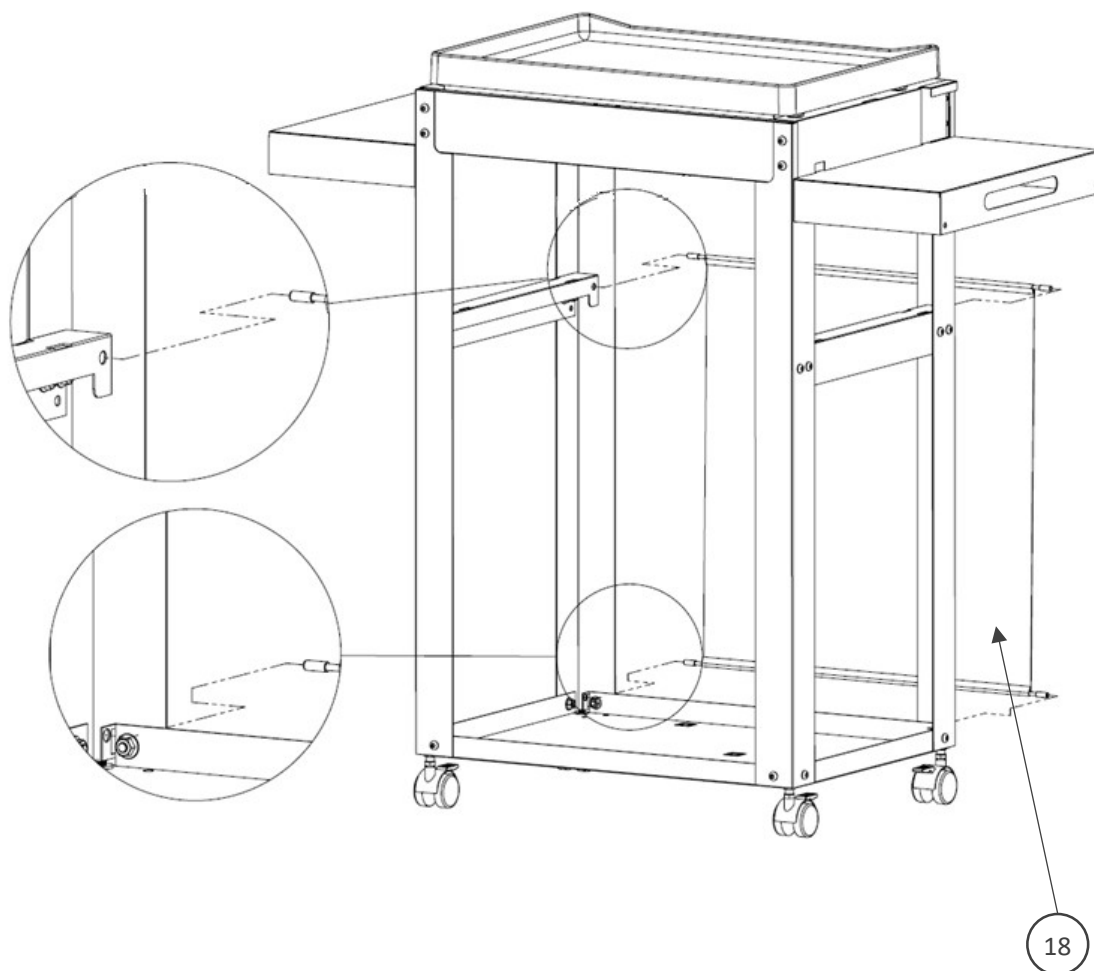

Contrôlé par:

Pour toute réclamation Complaints / Indien u een klacht heeft

Contactez notre Service Après-ventes par email sav@lemarquier.com

Please contact our after-sales services by e-mail sav@lemarquier.com

Gelieve contact op te nemen met onze dienst na verkoop via email op sav@lemarquier.com

lemarquier.com